

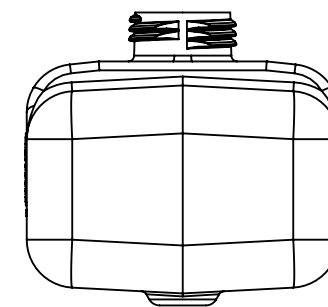

REVISIONS					
REV	ECR	DESCRIPTION	DATE	BY	APR
A	NPN	RELEASED FOR PRODUCTION	10-21-14	ANA	SAB

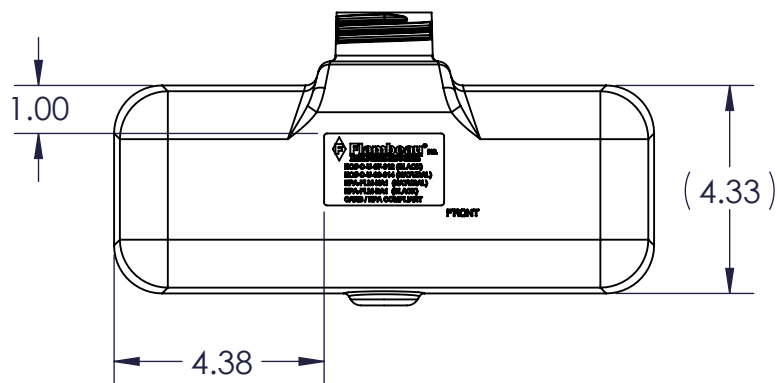
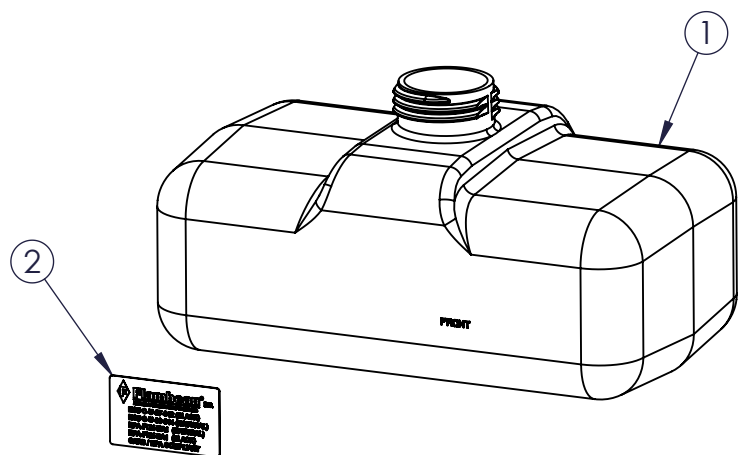
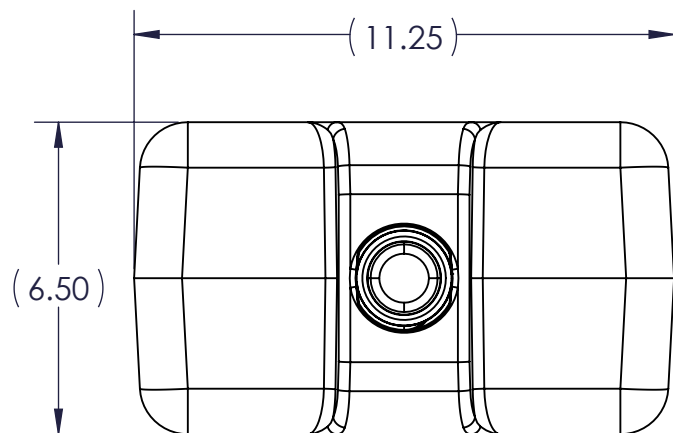

2	477026x	477026	CARB/EPA FUEL TANK LABEL	1
1	070781A-FL	4012-1	1 GALLON TANK, 2 1/4" NECK, BLK	1
ITEM	FPN	DWG #	DESCRIPTION	QTY
PROPRIETARY AND CONFIDENTIAL THE INFORMATION CONTAINED IN THIS DRAWING IS THE SOLE PROPERTY OF FLAMBEAU, INC. ANY REPRODUCTION IN PART OR AS A WHOLE WITHOUT THE WRITTEN PERMISSION OF FLAMBEAU, INC. IS PROHIBITED.		SHT 1	 FLAMBEAU, INC.	
DIMENSIONS ARE IN INCHES. THE FOLLOWING TOLERANCES APPLY UNLESS OTHERWISE SPECIFIED ANGULAR: ±3° TWO PLACE x.xx ±.125" THREE PLACE x.xxx ±.060" DIMENSIONS IN PARENTHESIS () ARE FOR REFERENCE ONLY.			OF 1	SCALE: 1:4 MOLD NO: 4012 DESCRIPTION: ONE GALLON CARB/EPA FUEL TANK ASSEMBLY
			CUSTOMER: US PLASTICS	DWG NO: 071398

CUSTOMER SIGN-OFF	
COMPANY:	
SIGNATURE:	
PRINTED NAME:	
DATE:	